

AC GENERATION - DESCRIPTION AND OPERATION

1. General

- A. This section gives a general description and the operation of the AC generation components for the cabin universal AC outlets. The components include the 500 VA Inverter, Power Controller, AC Universal Outlets, and the 115 VAC switch found on the left switch panel. The passenger models have four universal outlets installed, two in the aft cabin and two in the flight compartment area. The super cargomaster models have two universal outlets installed in the flight compartment area.

2. Description

- A. 500 VA Inverter (Refer to Figure 1).
- (1) The 500 VA inverter (UT002) is found on the right side of the aft passenger compartment at FS 361.68, WL 103.95. The static-type inverter changes 28 VDC electrical current into a 115 VAC (60 Hz) sine wave (single phase) current output. The inverter has a crystal-controlled oscillator for output frequency stability and a pulse-width-modulated square-to-sine wave power conversion function for efficient operation. The AC voltage supplied by the inverter is used to supply airborne equipment. These equipment items can include entertainment systems, televisions, computers and other equipment.
- B. Power Controller (Refer to Figure 1).
- (1) The Power Controller (BF001) is found at approximately FS 237.50 and FS 256.00 near the right center line, under the floor panels. It is installed on mounting plates with screws. The controller has a total of five electrical connectors. One electrical connector is an input where AC electrical power is supplied from the 500 VA Inverter (UT002). The four output connectors supply AC electrical power to the universal outlets. The controller has a sensing circuit that monitors the current supplied to each outlet. If a fault condition is detected, the suspect outlet power is turned off (tripped). If an outlet is in a tripped condition the corresponding LED will come on.
- C. The Universal AC outlets (Refer to Figure 1).
- (1) The super cargomaster has a total of two universal outlets installed in the flight compartment area, one on the left (UC017) and one on the right (UF002) side of the flight compartment at FS 175.95. The passenger models have two additional outlets installed at approximately FS 248.00 with one on the left (UC018) and one on the right (UF003) side of the cabin. Each of the outlets is installed at approximately WL 106.00. The power to the outlets are shut off when the 115 VAC switch (SI029) on the left switch panel is set to the OFF position.

3. Operation

- A. AC Generation System (Cabin Power Outlets)
- (1) The 500 VA Inverter receives a 28 VDC input from the 115 VAC PWR INVRT circuit breaker, found on the Left Circuit Breaker Panel. The inverter then changes the voltage from direct current (DC) to alternating current (AC). The inverter then supplies the 115 VAC (230 VAC optional) to the Power Controller in the cabin for distribution to the outlets. The Power Controller is supplied 28 VDC from the 115 VAC OUTLET CTRLR circuit breaker, found on the left circuit breaker panel. The Power Controller supplies sufficient electrical current to operate four outlets in the cabin. Two of the cabin outlets are found in the forward in the flight compartment area and two are found aft in the cabin on the passenger model configurations. The universal outlets power is turned off when the 115 VAC (SI029) switch on the left circuit breaker switch panel is set to the OFF position and disconnects the electrical power to the controller. With the switch in the ON position, 28 VDC is supplied to the Power Controller and the outlets are then operational.

Figure 1 : Sheet 1 : AC Generation Components Installation

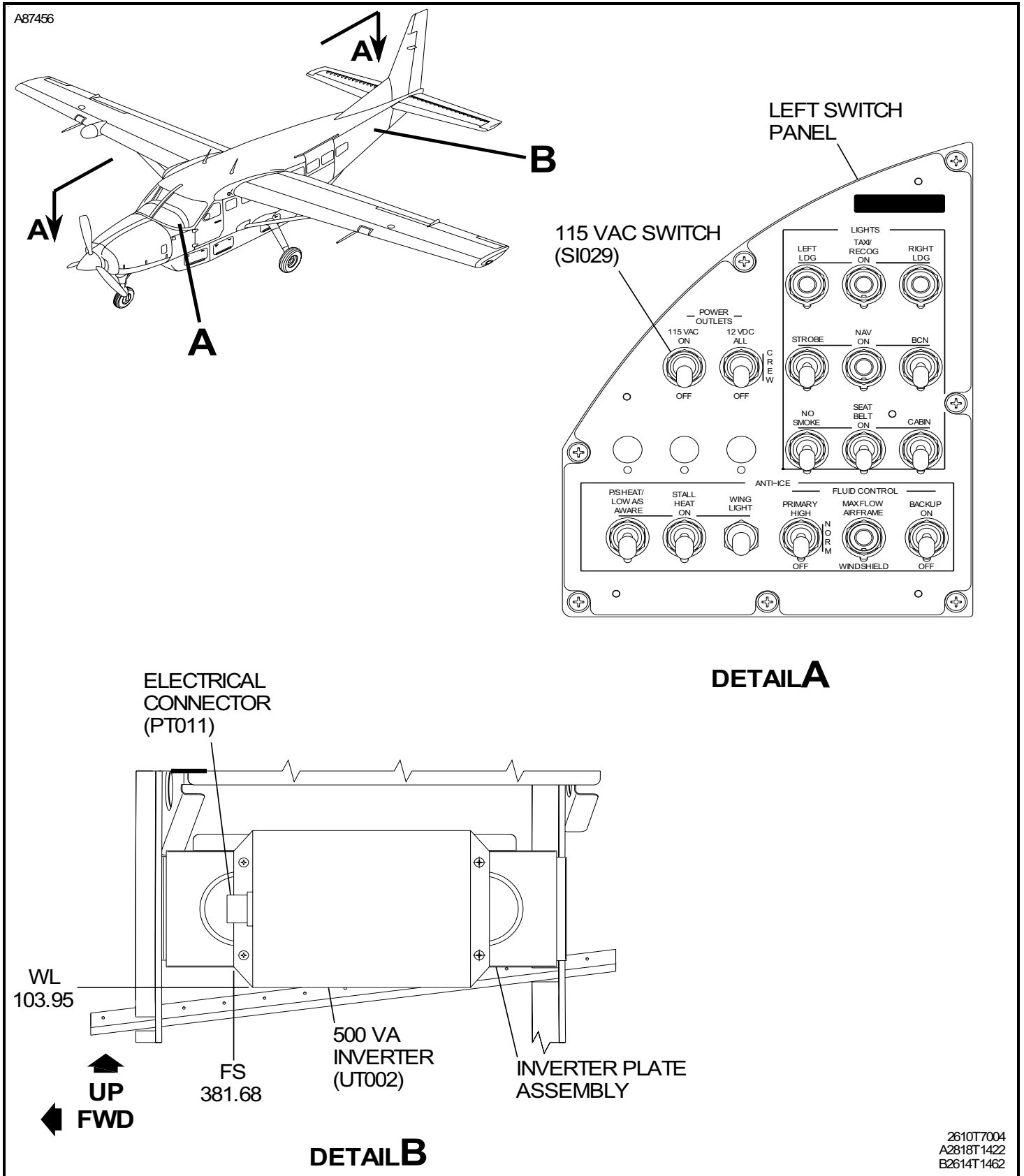

Figure 1 : Sheet 2 : AC Generation Components Installation

